

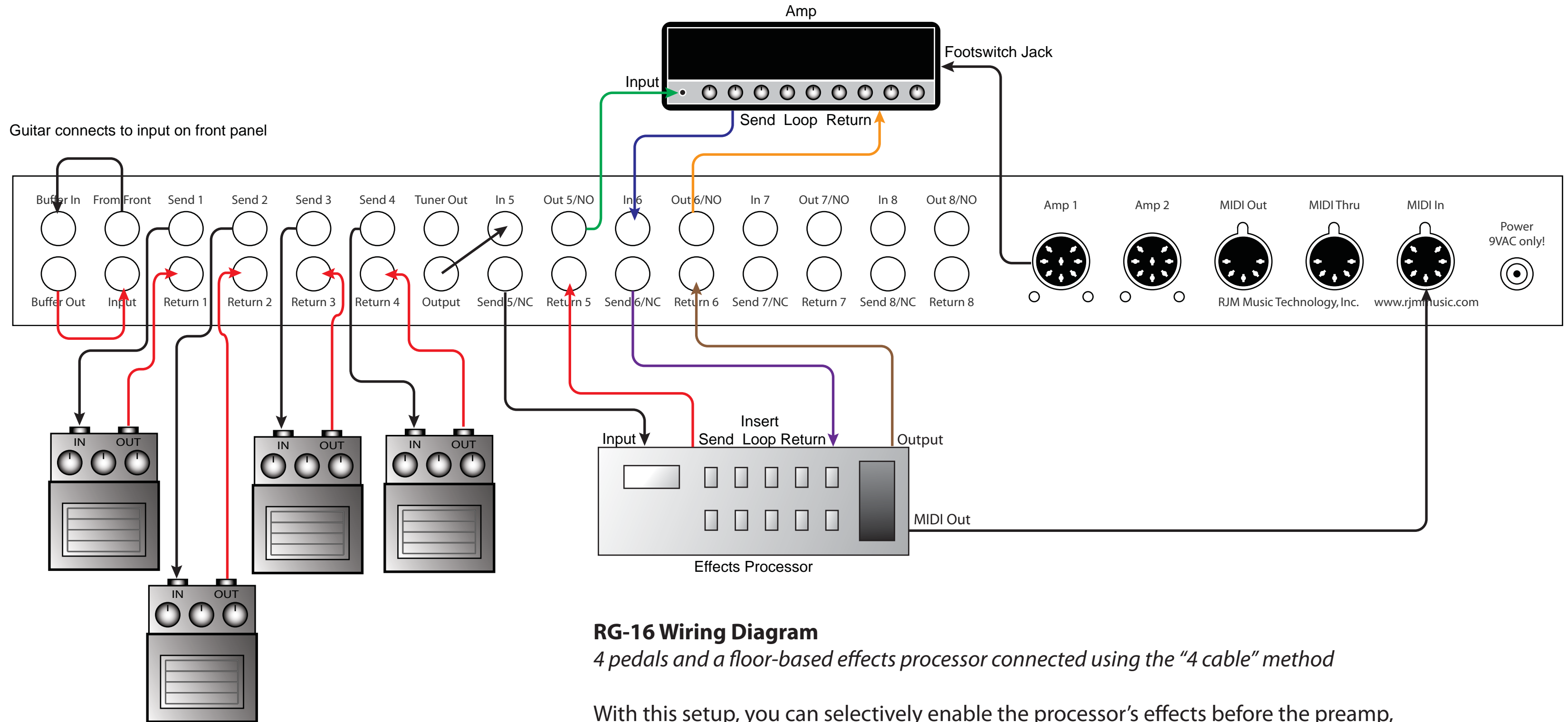

RG-16 Wiring Diagram



RG-16 Wiring Diagram

4 pedals and a floor-based effects processor connected using the "4 cable" method

With this setup, you can selectively enable the processor's effects before the preamp, after the preamp, or use only the processor and bypass the amp's preamp entirely.

- Effects processor bypassed:** Turn Loop 4 off, Loop 5 off
- Effects before preamp only:** Turn Loop 4 on, Loop 5 off, enable Insert Loop in processor
- Effects after preamp only:** Turn Loop 4 off, Loop 5 on, enable Insert Loop in processor
- Effects before and after preamp:** Turn Loop 4 on, Loop 5 on, enable Insert Loop in processor
- Effects only, no preamp:** Turn Loop 4 on, Loop 5 on, disable Insert Loop in processor