

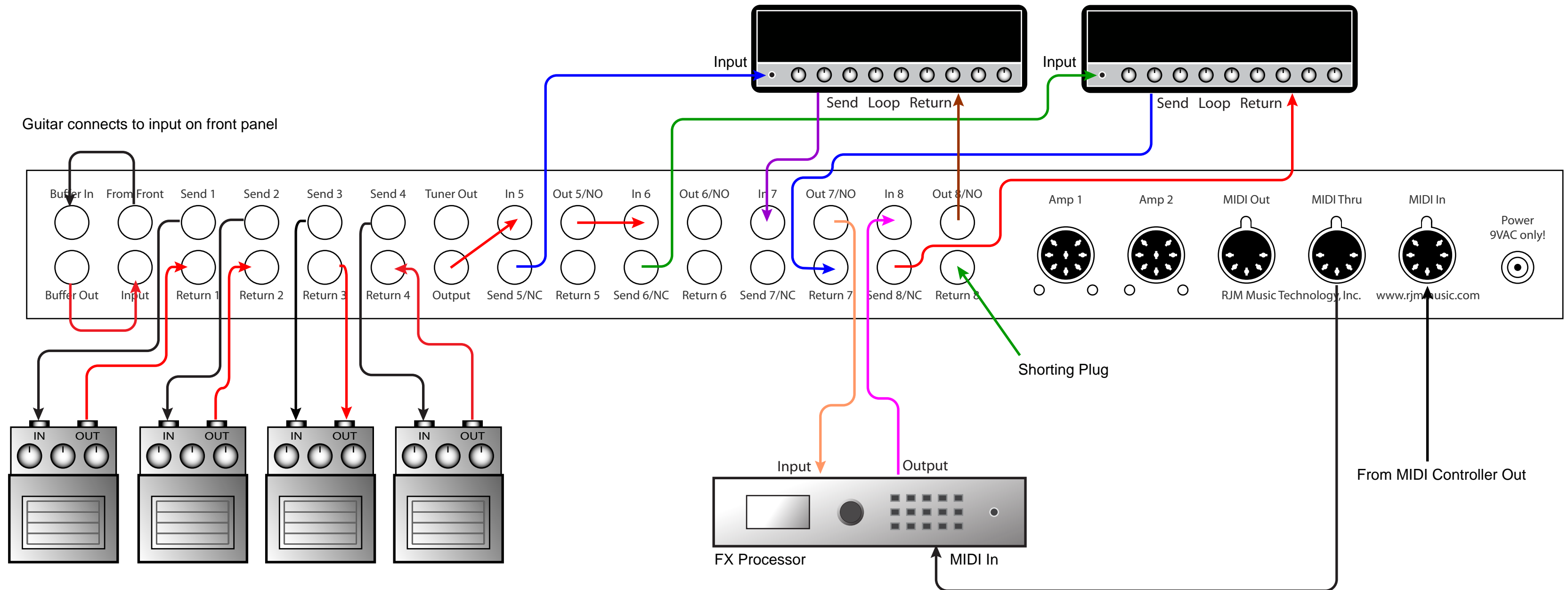

# RG-16 Wiring Diagram



## RG-16 Wiring Diagram

4 pedals, 2 amps, 1 effects processor shared between both amps

**Don't try this unless you're willing to put in some debugging effort!** You will likely run into grounding and/or level problems. Using an isolation transformer in one or both amps' effects loops should get rid of hum due to ground loops. You will need carefully balance the input and output levels of the effects processor and both amps.

To activate amp 1: turn loop 5 on and loops 6, 7 and 8 off  
To activate amp 2: turn loop 5 off and loops 6, 7 and 8 on  
The effects processor will be connected to the active amp

A shorting plug (a 1/4" plug with the top connected to ground) must be plugged into the Return 8 jack.